

Specifications

| Model | Z-60 DC & Z-60 FE | |
|--|-------------------|------------------|
| Measurements | Metric | US |
| Working height maximum* | 20.16 m | 65 ft 7 in |
| Platform height maximum | 18.16 m | 59 ft 7 in |
| Horizontal reach maximum | 11.15 m | 36 ft 7 in |
| Up and over clearance maximum | 7.39 m | 24 ft 3 in |
| Below ground reach | 2.46 m | 8 ft 1 in |
| A Platform length - 8 ft / 6 ft model | 0.91 m / 0.76 m | 3 ft / 2 ft 6 in |
| B Platform width - 8 ft / 6 ft model | 2.44 m / 1.83 m | 8 ft / 6 ft |
| C Height - stowed | 2.54 m | 8 ft 4 in |
| Height - transport (jib tucked under) | 2.62 m | 8 ft 7 in |
| D Length - stowed | 8.15 m | 26 ft 9 in |
| Length - transport (jib tucked under) | 6.30 m | 20 ft 8 in |
| E Width | 2.49 m | 8 ft 2 in |
| F Wheelbase | 2.49 m | 8 ft 2 in |
| G Ground clearance - center | 0.33 m | 1 ft 1 in |

Productivity

| | | |
|----------------------------------|---------------------|------------|
| Lift capacity | 227 kg | 500 lbs |
| Platform rotation | 160° | 160° |
| Vertical jib rotation | 135° | 135° |
| Turntable rotation | 355° non-continuous | |
| Turntable tailswing - riser up | 0.58 m | 1 ft 11 in |
| Turntable tailswing - riser down | 0.81 m | 2 ft 8 in |
| Drive speed - stowed | 6.44 km/h | 4.0 mph |
| Drive speed - raised** | 1.09 km/h | 0.68 mph |
| Gradeability - 4WD - stowed*** | 45% | 45% |
| Turning radius - inside | 2.51 m | 8 ft 3 in |
| Turning radius - outside | 5.69 m | 18 ft 8 in |
| Controls | 24V DC proportional | |
| Tyres | 355/55D 625 | |

Power

| | | |
|-------------------------|---|--------|
| Drive system | 34 V 3-Phase AC | |
| Power source | 48 V DC (eight 6V batteries) 390 Ah capacity (FLA standard on DC) 415 Ah capacity (AGM standard on FE) 24.8 hp (18.5kW) Kubota D1105 Stage V driven AC generator (FE only) | |
| Auxiliary power unit | 12V DC | 12V DC |
| Hydraulic tank capacity | 68.14 L | 18 gal |
| Fuel tank capacity | 64.35 L | 17 gal |

Sound & Vibration Levels

| | |
|---|--|
| Sound pressure level (ground workstation) | 70 dBA (DC) / 77 dBA (FE) |
| Sound pressure level (platform workstation) | 70 dBA (DC) / 72 dBA (FE) |
| Vibration | 0.553 m/s ² (1.81 ft/s ²) |

Weight****

| | | |
|---------|----------|------------|
| Z-60 DC | 7,530 kg | 16,600 lbs |
| Z-60 FE | 7,756 kg | 17,100 lbs |

Standards Compliance

EU Directives: 2006/42/EC - Machinery (harmonized standard EN280), European Emissions Regulation (EU) 2016/1628 Stage V; 2004/108/EC (EMC); 2000/14/EC (Outdoor Noise)

Range Of Motion Z-60 DC & Z-60 FE

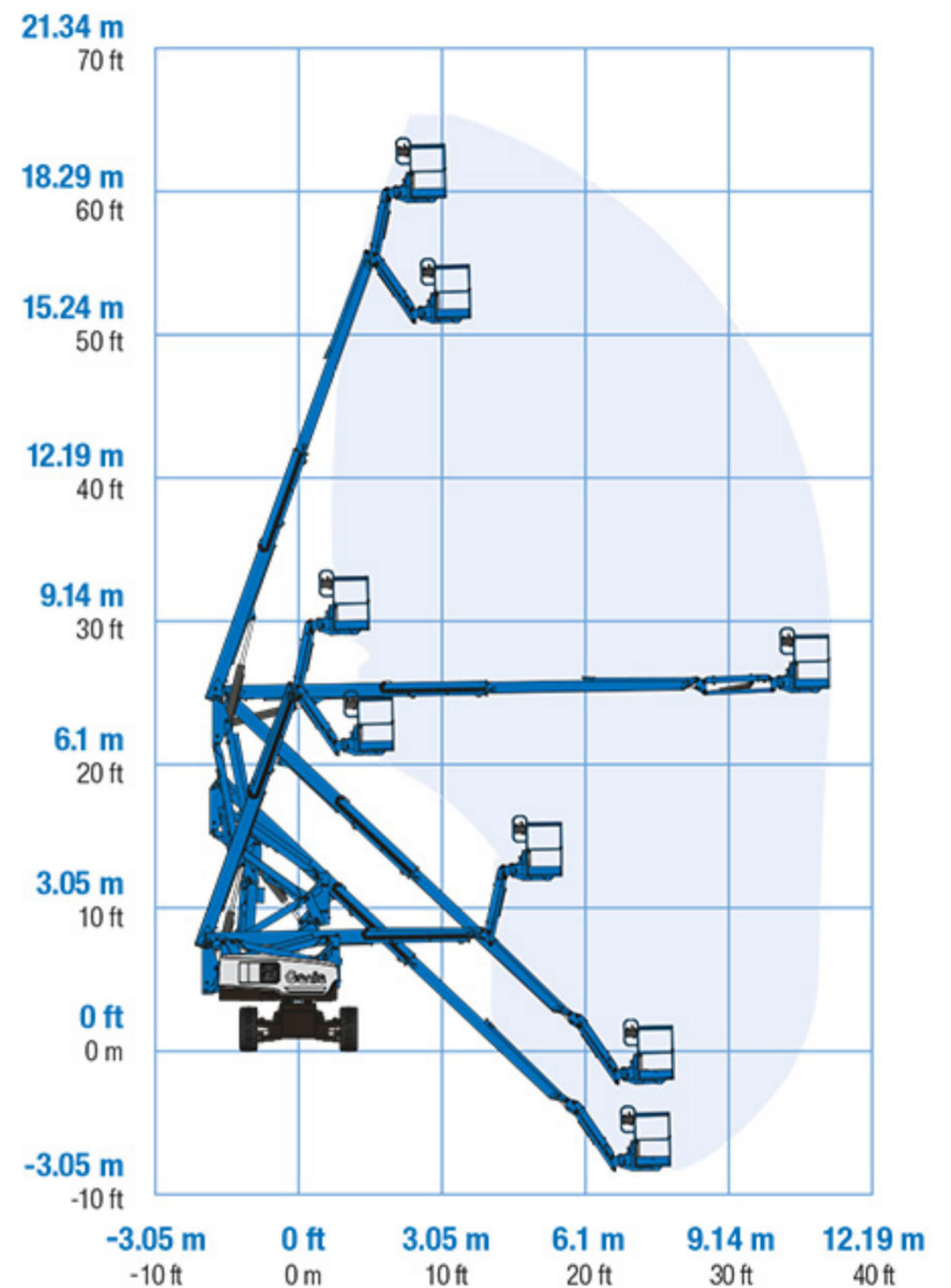

* The metric equivalent of working height adds 2 m to platform height. U.S. adds 6 ft to platform height.
** In lift mode (platform raised), the machine is designed to operate on firm, level surfaces only.
*** Gradeability applies to driving on slopes. See operators manual for details regarding slope ratings.
**** Weight will vary depending on options and/or country standards.

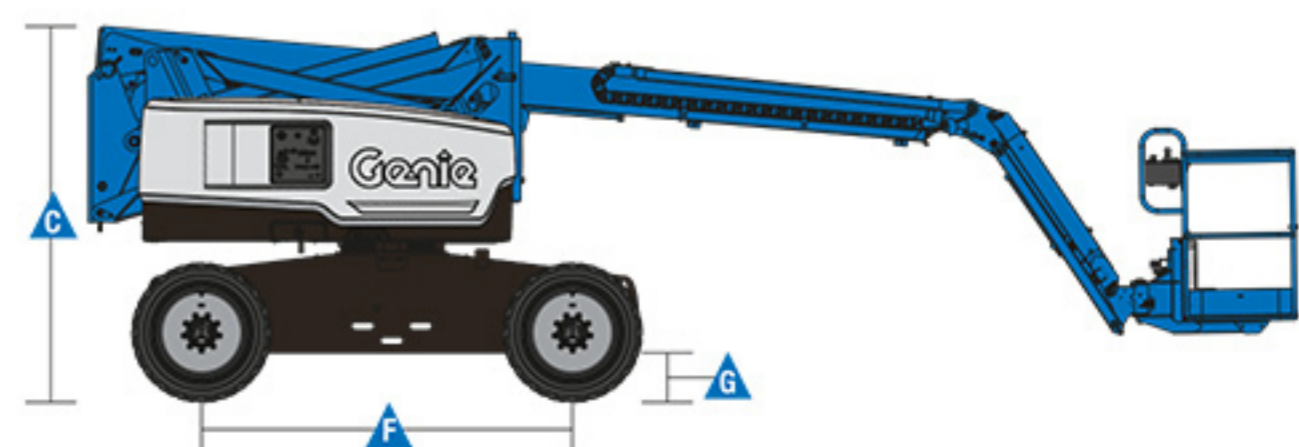
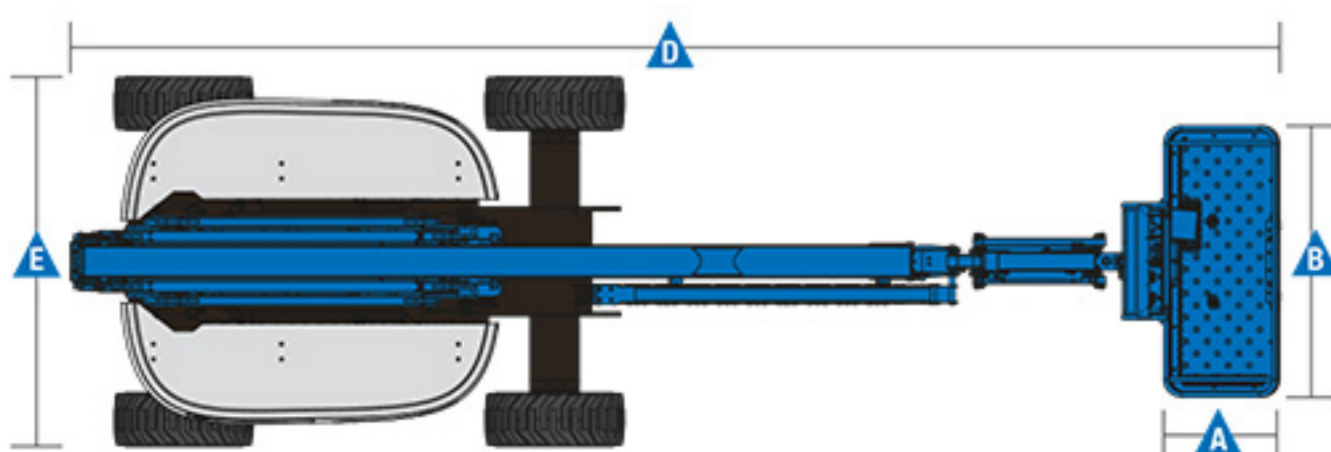

Features

| Standard Features | Easily Configured To Meet Your Needs | Options & Accessories |
|-------------------|--------------------------------------|-----------------------|
|-------------------|--------------------------------------|-----------------------|

Measurements

- 20.16 m (65 ft 7 in) working height
- 11.15 m (36 ft 7 in) horizontal reach
- 7.40 m (24 ft 3 in) up and over clearance
- Up to 227 kg (500 lbs) lift capacity

Productivity

- Digital hour meter with battery charge indicator and diagnostic readout
- 4 Wheel AC electric drive system
- Variable speed high efficiency hydraulic power unit
- Self-leveling platform
- Hydraulic platform rotation
- Proportional joystick controls
- Telematics Ready Connector
- Thumb rocker steering
- Drive enable
- Chassis tilt drive function cut-out
- AC power cord to platform
- Horn
- Hour meter
- Tilt alarm
- Descent & travel alarms
- Flashing beacon
- 355° non-continuous turntable rotation
- Locking turntable covers
- Positive traction drive
- Dual parallelogram for vertical wall tracking
- Lift Guard™ Contact Alarm
- Tool Tray

Power

- 48 V DC battery pack (390Ah FLA standard on DC)
- 48 V DC battery pack (415Ah AGM standard on FE)
- 12V DC auxiliary power
- 25A temperature compensated smart charge system
- Battery charge indicator
- Low battery voltage interrupt

Platform Options

- Steel 1.83 m (6 ft) dual entry with side swing gate (standard)
- Steel 2.44 m (8 ft) tri entry with side swing gate

Jib

- 1.52 m (5 ft) jib boom with 135° working range

Engine (FE only)

- 18.5 kW (24.8 hp) Kubota Stage V diesel

Drive

- 4WD Electric AC (standard)

Axle

- Active oscillation (standard)

Tyre Options

- Rough terrain non-marking foam filled (standard)
- Rough terrain foam-filled

Productivity Options

- Lift Guard™ Half mesh platform panels⁽¹⁾
- Platform auxiliary top rail
- Air line to platform
- Power to platform: plug, socket, with optional Residual-current Circuit Breaker with Overcurrent protection
- Work lights package (2 on chassis, 2 on platform)⁽¹⁾
- Dual axis joystick steering⁽¹⁾
- Biodegradable hydraulic oil
- Hostile environment kit: cylinder bellows, boom wiper seals platform and ground control box covers⁽¹⁾
- Chassis tilt lift function cut-out (software setting)
- Panel cradle package⁽¹⁾
- Lockable platform control box covers
- Tow package⁽¹⁾
- Operator Protective Structure⁽²⁾
- Lift Guard™ Fall Arrest Bar⁽²⁾

Power Options

- 2000W 120V/60Hz, 240V/50Hz or 110V/50Hz power inverter
- FLA (flooded lead acid) batteries (standard on DC)
- AGM maintenance-free batteries (standard on FE)
- Low temperature cut-out module



⁽¹⁾ Factory-fit option only
⁽²⁾ Aftermarket only

Europe, Middle East, Africa and Russia Region

United Kingdom and Europe, T: +44 800 988 3739 (toll free) or +31 165 519 349
Middle East, Southern Africa, Russia and Turkey, T: +971 4 399 0381
Visit www.genielift.com/en-gb/about-genie/locations to view our global locations list

Worldwide Manufacturing And Distribution

Australia • Brazil • Caribbean • Central America • China • France • Germany • Italy • Japan • Korea • Mexico • Russia • Southeast Asia • Spain • Sweden • United Arab Emirates • United Kingdom • United States

Product specifications and prices are subject to change without notice or obligation. The photographs and/or drawings in this document are for illustrative purposes only. Refer to the appropriate Operator's Manual for instructions on the proper use of this equipment. Failure to follow the appropriate Operator's Manual when using our equipment or to otherwise act irresponsibly may result in serious injury or death. The only warranty applicable to our equipment is the standard written warranty applicable to the particular product and sale and we make no other warranty, express or implied. Products and services listed may be trademarks, service marks or trade names of Terex Corporation and/or their subsidiaries in the USA and many other countries. Genie is a registered trademark of Terex South Dakota, Inc. © 2020 Terex Corporation.

